



**INSTITUTO DE CIENCIAS
DE LA CONSTRUCCIÓN
EDUARDO TORROJA**

C/ Serrano Galvache n. 4 28033 Madrid (Spain)
Tel.: (34) 91 302 04 40 Fax: (34) 91 302 07 00
direccion.ietcc@csic.es <https://dit.ietcc.csic.es>

**European Technical
Assessment**

**ETA 20/1288
of 11/06/2024**

English translation prepared by IETcc. Original version in Spanish language

General Part

Technical Assessment Body issuing the ETA designated according to Art. 29 of Regulation (EU) 305/2011:

Instituto de Ciencias de la Construcción Eduardo Torroja (IETcc)

Trade name of the construction product:

TRSA / TRSAK

Product family to which the construction product belongs:

Deformation controlled anchor made of galvanized steel of sizes M6, M8, M10, M12, M16 and M20 for use in non-cracked concrete

Manufacturer:

Thale Sp. z.o.o Sp. k.
Wilimowo 2
11-041 Olsztyn, Poland.
website: www.niczuk.pl

Manufacturing plants:

Thale plant 2

This European Technical Assessment contains:

10 pages including 3 annexes which form an integral part of this assessment.

This European Technical Assessment is issued in accordance with regulation (EU) No 305/2011, on the basis of:

European Assessment Document EAD 330232-00-0601 "Mechanical Fasteners for use in concrete", ed. October 2016

This ETA is a corrigendum of:

ETA 09/02/2021, issued on 09/02/2021

Código seguro de Verificación : GEN-8de3-3600-4e8e-f619-2de0-6e8b-1113-7acf | Puede verificar la integridad de este documento en la siguiente dirección : <https://sede.administracion.gob.es/pagSedeFront/servicios/consultaCSV.htm>

CSV : GEN-8de3-3600-4e8e-f619-2de0-6e8b-1113-7acf

DIRECCIÓN DE VALIDACIÓN : <https://sede.administracion.gob.es/pagSedeFront/servicios/consultaCSV.htm>

FIRMANTE(1) : ANGEL CASTILLO TALAVERA | FECHA : 11/06/2024 10:56 | Sin acción específica



English translation prepared by IETcc

This European Technical Assessment is issued by the Technical Assessment Body in its official language. Translations of this European Technical Assessment in other languages shall fully correspond to the original issued document and should be identified as such.

This European Technical Assessment may be withdrawn by the issuing Technical Assessment Body, in particular pursuant to information by the Commission according to article 25 (3) of Regulation (EU) No 305/2011.

Código seguro de Verificación : GEN-8de3-3600-4e8e-f619-2de0-6e8b-1113-7acf | Puede verificar la integridad de este documento en la siguiente dirección :
<https://sede.administracion.gob.es/pagSedeFront/servicios/consultaCSV.htm>

CSV : GEN-8de3-3600-4e8e-f619-2de0-6e8b-1113-7acf

DIRECCIÓN DE VALIDACIÓN : <https://sede.administracion.gob.es/pagSedeFront/servicios/consultaCSV.htm>

FIRMANTE(1) : ANGEL CASTILLO TALAVERA | FECHA : 11/06/2024 10:56 | Sin acción específica



SPECIFIC PART

1. Technical description of the product

The Thale TRSA / TRSAK in the range of M6 to M20 is an anchor made of galvanised steel, which is placed into a drilled hole and anchored by deformation-controlled expansion. The anchorage is characterised by friction between the sleeve and concrete.

The product and its description are shown in annex A.

2. Specification of the intended use in accordance with the applicable European Assessment Document.

The performances given in section 3 are only valid if the anchor is used in compliance with the specifications and conditions given in annex B.

The verifications and assessment methods on which this European Technical Assessment is based, lead to the assumption of a working life of the anchor of at least 50 years. The indications given on the working life cannot be interpreted as a guarantee given by the producer, but are to be regarded only as a mean to choosing the right products in relation to the expected economically reasonable working life of the works.

3. Performance of the product and references to the methods used for its assessment

3.1 Mechanical resistance and stability (BWR 1)

Essential characteristic	Performance
Characteristic resistance under static or quasi static loading	See annexes C1 to C3
Displacements under tension and shear loads	See annexes C2 and C3

3.2 Safety in case of fire (BWR 2)

Essential characteristic	Performance
Reaction to fire	Anchorage satisfy requirements for class A1

3.3 Hygiene, health and the environment (BWR 3)

This requirement is not relevant for the anchors.

3.4 Safety in use (BWR 4)

The essential characteristics regarding safety in use are included under the basic works requirements Mechanical resistance and stability.

3.5 Protection against noise (BWR 5)

This requirement is not relevant for the anchors.



English translation prepared by IETcc

3.6 Energy economy and heat retention (BWR 6)

This requirement is not relevant for the anchors.

3.7 Sustainable use of natural resources (BWR 7)

No performance assessed.

4. Assessment and Verification of Constancy of Performances (hereinafter AVCP) system applied, with reference to its legal base

The applicable European legal act for the system of Assessment and Verification of Constancy of Performances (see annex V to Regulation (EU) No 305/2011) is 96/0582/EC.

The system to be applied is 1.

5. Technical details necessary for the implementation of the AVCP system, as provided for in the applicable European Assessment Document.

The technical details necessary for the implementation of the AVCP system are laid down in the quality plan deposited at Instituto de Ciencias de la Construcción Eduardo Torroja.



Instituto de Ciencias de la Construcción Eduardo Torroja
CONSEJO SUPERIOR DE INVESTIGACIONES CIENTÍFICAS

C/ Serrano Galvache n.º 4. 28033 Madrid.
Tel: (+34) 91 302 04 40 Fax. (+34) 91 302 07 00
<https://dit.ietcc.csic.es>



On behalf of the Instituto de Ciencias de la Construcción Eduardo Torroja
Madrid, 11th of June 2024

Director IETcc-CSIC



Product

TRSA, TRSAK anchor

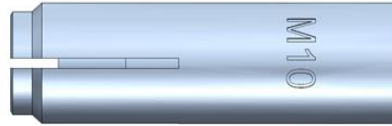

TRSA anchor

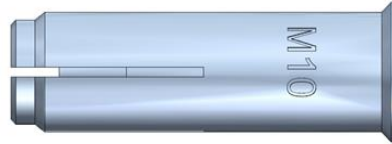

TRSAK anchor

Identification on sleeve: Thale logo + “TRSA (TRSAK)” + Metric

Anchor dimensions	M6	M8	M10	M12	M16	M20
ØD: External diameter [mm]	8	10	12	15	20	25
Ød: internal diameter [mm]	M6	M8	M10	M12	M16	M20
L: total length [mm]	25	30	40	50	65	80

Setting tool

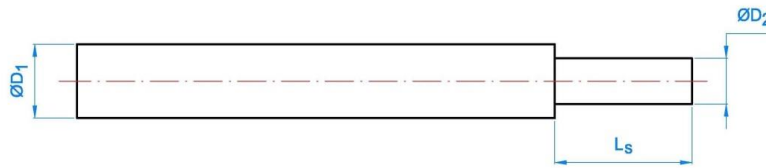

Setting tool dimensions	M6	M8	M10	M12	M16	M20
Ø D ₁ [mm]	7,5	9,5	11,5	14,5	18,0	22,0
Ø D ₂ [mm]	5,0	6,5	8,0	10,2	13,5	16,5
L _s [mm]	15	18	21	30	36	48

Setting tool could be assembled with a plastic handle for hand protection purposes

TRSA, TRSAK anchor

Product description

Product

Annex A1

Código seguro de Verificación : GEN-8de3-3600-4e8e-f619-2de0-6e8b-1113-7acf | Puede verificar la integridad de este documento en la siguiente dirección : <https://sede.administracion.gob.es/pagSedeFront/servicios/consultaCSV.htm>



Installed condition

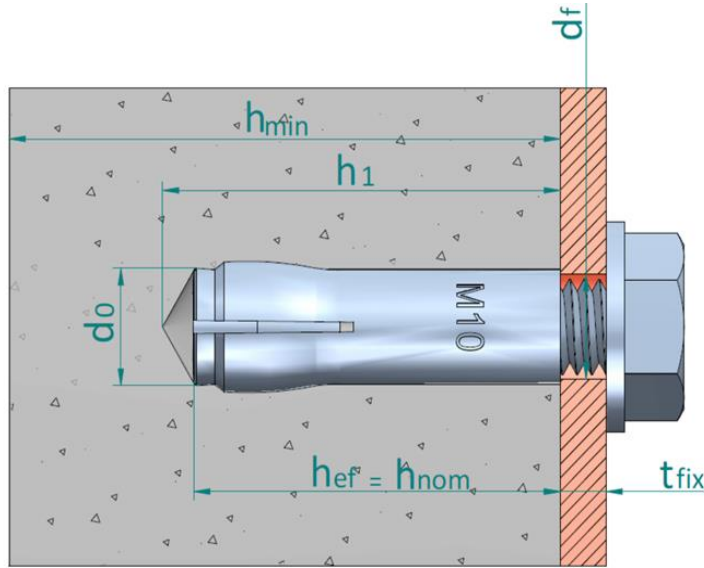

- h_{ef} : Effective anchorage depth
- h_1 : Depth of drilled hole
- h_{nom} : Overall anchor embedment depth in the concrete
- h_{min} : Minimum thickness of concrete member
- t_{fix} : Thickness of fixture
- d_o : Nominal diameter of drill bit
- d_f : Fixture clearance hole diameter

Table A1: materials

Item	Designation	Material for TRSA / TRSAK
1	Sleeve	Carbon steel wire rod, zinc plated $\geq 5 \mu\text{m}$ ISO 4042 A2
2	Cone	Carbon steel wire rod, zinc plated $\geq 5 \mu\text{m}$ ISO 4042 A2
3	Plastic retainer	PVC

TRSA, TRSAK anchor

Product description

Installed condition and Materials

Annex A2



Specifications of intended use

Anchorage subjected to:

- Static or quasi static loads

Base materials:

- Reinforced or unreinforced normal weight concrete according to EN 206-1:2008
- Strength classes C20/25 to C50/60 according to EN 206-1:2008
- Uncracked concrete

Use conditions (environmental conditions):

- Anchorages subjected to dry internal conditions.

Design:

- Anchorages are designed under the responsibility of an engineer experienced in anchorages and concrete.
- Verifiable calculation rules and drawings are prepared taking into account of the loads to be anchored. The position of the anchor is indicated on the design drawings (e.g. position of the anchor relative to reinforcement or to supports, etc.).
- Anchorages under static or quasi-static actions are designed for design method A in accordance with:
 - EN 1992-4:2018

Installation:

- Hole drilling by rotary plus hammer mode.
- Anchor installation carried out by appropriately qualified personal and under the supervision of the person responsible for technical matters of the site.
- In case of aborted hole: new drilling at a minimum distance away of twice the depth of aborted hole or smaller distance if the aborted hole is filled with high strength mortar and if under shear or oblique tension load it is not the direction of the load application.
- The bolt or threaded rod to be used shall be property class 4.6 / 5.6 / 5.8 / 6.8 or 8.8 according to ISO 898-1.
- The length of the bolt shall be determined as:
 - Minimum bolt length = $t_{fix} + l_{s,min}$
 - Maximum bolt length = $t_{fix} + l_{s,max}$

TRSA, TRSAK anchor

Intended use

Specifications

Annex B1



Table C1: Installation parameters for TRSA, TRSAK anchor

Installation parameters			Performances					
			M6	M8	M10	M12	M16	M20
d_o	Nominal diameter of drill bit:	[mm]	8	10	12	15	20	25
D	Thread diameter:	[mm]	M6	M8	M10	M12	M16	M20
d_f	Fixture clearance hole diameter \leq	[mm]	7	9	12	14	18	22
T_{inst}	Maximum installation torque:	[Nm]	4	11	17	38	60	100
$l_{s,min}$	Minimum screwing depth:	[mm]	6	8	10	12	16	20
$l_{s,max}$	Maximum screwing depth:	[mm]	10	13	17	21	27	34
h_{min}	Minimum thickness of concrete member:	[mm]	100	100	100	100	130	160
h_1	Depth of drilled hole:	[mm]	27	33	43	54	70	86
h_{nom}	Overall anchor embedm. depth in the concrete:	[mm]	25	30	40	50	65	80
h_{ef}	Effective anchorage depth:	[mm]	25	30	40	50	65	80
s_{min}	Minimum allowable spacing:	[mm]	60	60	80	100	130	160
c_{min}	Minimum allowable distance:	[mm]	105	105	140	175	230	280

Installation process

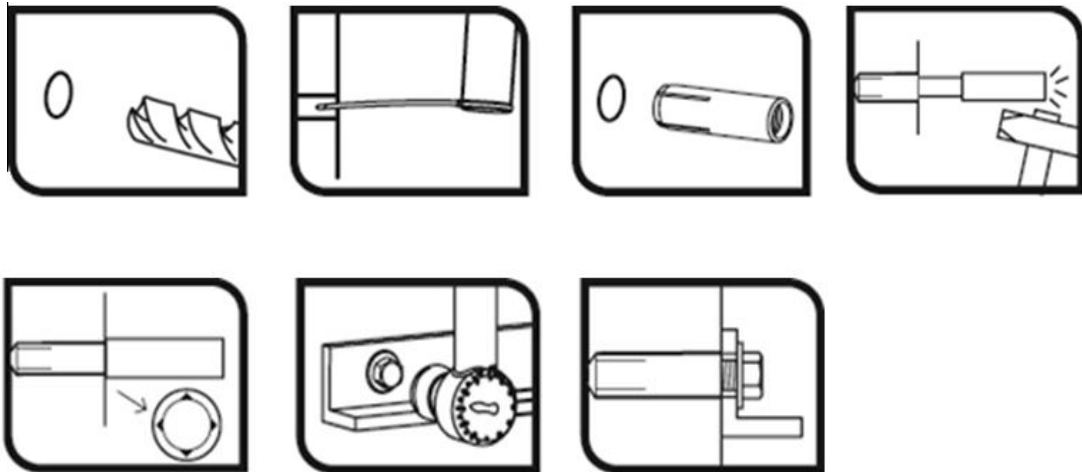

TRSA, TRSAK anchor

Performances

Installation parameters and installation procedure

Annex C1



Table C2: Characteristic values to tension loads of design method A according to EN 1992-4 for TRSA, TRSAK anchor

Characteristic values of resistance to tension loads of design according to design method A		Performances						
		M6	M8	M10	M12	M16	M20	
Tension loads: steel failure								
$N_{Rk,s}$	Tension steel char. resistance, steel class 4.6: [kN]	8,0	14,6	23,2	33,7	62,8	98,0	
γ_{Ms}	Partial safety factor: [-]	2,0	2,0	2,0	2,0	2,0	2,0	
$N_{Rk,s}$	Tension steel char. resistance, steel class 4.8: [kN]	8,0	14,6	18,2	33,7	62,8	95,1	
γ_{Ms}	Partial safety factor: [-]	1,5	1,5	1,5	1,5	1,5	1,5	
$N_{Rk,s}$	Tension steel char. resistance, steel class 5.6: [kN]	10,1	18,3	18,2	42,2	78,5	122,5	
γ_{Ms}	Partial safety factor: [-]	2,0	2,0	1,5	2,0	2,0	2,0	
$N_{Rk,s}$	Tension steel char. resistance, steel class 5.8: [kN]	10,1	17,6	18,2	35,1	65,0	95,1	
γ_{Ms}	Partial safety factor: [-]	1,5	1,5	1,5	1,5	1,5	1,5	
$N_{Rk,s}$	Tension steel char. resistance, steel class 6.8 [kN]	12,1	17,6	18,2	35,1	65,0	95,1	
γ_{Ms}	Partial safety factor: [-]	1,5	1,5	1,5	1,5	1,5	1,5	
$N_{Rk,s}$	Tension steel char. resistance, steel class 8.8 [kN]	13,1	17,6	18,2	35,1	65,0	95,1	
γ_{Ms}	Partial safety factor: [-]	1,5	1,5	1,5	1,5	1,5	1,5	
Tension loads: pull-out failure in concrete								
$N_{Rk,p,ucr}$	Tension characteristic resistance in C20/25 uncracked concrete: [kN]	-- 1)	-- 1)	-- 1)	-- 1)	-- 1)	-- 1)	
ψ_c	Increasing factor for $N^0_{Rk,p}$:	C30/37 [-]	1,02	1,22	1,15	1,15	1,22	1,19
		C40/50 [-]	1,04	1,41	1,29	1,28	1,41	1,35
		C50/60 [-]	1,05	1,55	1,37	1,37	1,55	1,46
γ_{ins}	Installation safety factor: [-]	1,2	1,2	1,4	1,4	1,4	1,4	
Tension loads: concrete cone and splitting failure								
h_{ef}	Effective embedment depth: [mm]	25	30	40	50	65	80	
$k_{ucr,N}$	Factor for uncracked concrete: [-]	11.0						
γ_{ins}	Installation safety factor: [-]	1,2	1,2	1,4	1,4	1,4	1,4	
$s_{cr,N}$	Concrete cone failure: [mm]	3 x h_{ef}						
$c_{cr,N}$		1.5 x h_{ef}						
$s_{cr,sp}$	Splitting failure: [mm]	150	180	240	300	390	480	
$c_{cr,sp}$		75	90	120	150	195	240	
Displacements under tension loads								
N	Service tension load in uncracked concrete C20/25 to C50/60: [kN]	2,4	3,4	6,0	7,4	17,8	18,2	
δ_{N0}	Short term displacement under tension loads: [mm]	0,1	0,1	0,1	0,1	0,1	0,1	
$\delta_{N\infty}$	Long term displacement under tension loads: [mm]	0,3	0,3	0,3	0,3	0,3	0,3	

¹⁾ Pull out failure does not govern

TRSA, TRSAK anchor

Performances

Characteristic values for tension loads

Annex C2



Table C3: Characteristic values to shear loads of design method A according to EN 1992-4 for TRSA, TRSAK anchor

Characteristic values of resistance to shear loads of design according to design method A			Performances					
			M6	M8	M10	M12	M16	M20
Shear loads: steel failure without lever arm								
$V_{Rk,s}$	Shear steel char. resistance, steel class 4.6:	[kN]	4,0	7,3	11,6	16,8	31,4	49,0
γ_{Ms}	Partial safety factor:	[-]	1,67	1,67	1,67	1,67	1,67	1,67
$V_{Rk,s}$	Shear steel char. resistance, steel class 4.8:	[kN]	4,0	7,3	9,1	16,8	31,4	47,5
γ_{Ms}	Partial safety factor:	[-]	1,25	1,25	1,25	1,25	1,25	1,25
$V_{Rk,s}$	Shear steel char. resistance, steel class 5.6	[kN]	5,0	9,1	9,1	21,1	39,2	61,2
γ_{Ms}	Partial safety factor:	[-]	1,67	1,67	1,25	1,67	1,67	1,67
$V_{Rk,s}$	Shear steel char. resistance, steel class 5.8	[kN]	5,0	8,8	9,1	17,5	32,5	47,5
γ_{Ms}	Partial safety factor:	[-]	1,25	1,25	1,25	1,25	1,25	1,25
$V_{Rk,s}$	Shear steel char. resistance, steel class 6.8	[kN]	6,0	8,8	9,1	17,5	32,5	47,5
γ_{Ms}	Partial safety factor:	[-]	1,25	1,25	1,25	1,25	1,25	1,25
$V_{Rk,s}$	Shear steel char. resistance, steel class 8.8:	[kN]	6,5	8,8	9,1	17,5	32,5	47,5
γ_{Ms}	Partial safety factor:	[-]	1,25	1,25	1,25	1,25	1,25	1,25
Shear loads: steel failure with lever arm								
$M^0_{Rk,s}$	Characteristic bending moment, steel class 4.6	[Nm]	6,1	15,0	29,9	52,4	133,3	259,8
γ_{Ms}	Partial safety factor:	[-]	1,67	1,67	1,67	1,67	1,67	1,67
$M^0_{Rk,s}$	Characteristic bending moment, steel class 4.8	[Nm]	6,1	15,0	29,9	52,4	133,3	259,8
γ_{Ms}	Partial safety factor:	[-]	1,25	1,25	1,25	1,25	1,25	1,25
$M^0_{Rk,s}$	Characteristic bending moment, steel class 5.6	[Nm]	7,6	18,8	37,4	65,5	166,6	324,8
γ_{Ms}	Partial safety factor:	[-]	1,67	1,67	1,67	1,67	1,67	1,67
$M^0_{Rk,s}$	Characteristic bending moment, steel class 5.8	[Nm]	7,6	18,8	37,4	65,5	166,6	324,8
γ_{Ms}	Partial safety factor:	[-]	1,25	1,25	1,25	1,25	1,25	1,25
$M^0_{Rk,s}$	Characteristic bending moment, steel class 6.8	[Nm]	9,2	22,5	44,9	78,7	199,9	389,7
γ_{Ms}	Partial safety factor:	[-]	1,25	1,25	1,25	1,25	1,25	1,25
$M^0_{Rk,s}$	Characteristic bending moment, steel class 8.8	[Nm]	12,2	30,0	59,9	104,9	266,6	519,7
γ_{Ms}	Partial safety factor: ¹⁾	[-]	1,25	1,25	1,25	1,25	1,25	1,25
Shear loads: concrete pryout failure								
k_8	k_8 factor:	[-]	1,0	1,0	1,0	1,0	2,0	2,0
γ_{ins}	Installation safety factor:	[-]	1,0					
Shear loads: concrete edge failure								
l_f	Effective anchorage depth under shear loads:	[mm]	25	30	40	50	65	80
d_{nom}	Outside anchor diameter:	[mm]	8	10	12	15	20	25
γ_{ins}	Installation safety factor:	[-]	1,0					
Displacements under shear loads								
V	Service shear load in uncracked concrete C20/25 to C50/60:	[kN]	3,8	5,0	5,2	10,1	18,6	27,2
δ_{V0}	Short term displacement under shear loads:	[mm]	2,4	2,4	2,4	1,3	1,0	1,0
$\delta_{V\infty}$	Long term displacement under shear loads:	[mm]	3,5	3,5	3,5	2,0	1,5	1,5

TRSA, TRSAK anchor

Performances

Characteristic values for shear load.

Annex C3

