



**Technical and Test Institute
for Construction Prague**

Prosecká 811/76a
190 00 Prague
Czech Republic
eota@tzus.cz



Member of



www.eota.eu

European Technical Assessment

**ETA 17/0185
of 02/10/2017**

Technical Assessment Body issuing the ETA: Technical and Test Institute
for Construction Prague

Trade name of the construction product

Rawplug R-HPTIIA4 Stainless Steel
Throughbolts

**Product family to which the construction
product belongs**

Product area code: 33
Torque controlled expansion anchor
for use in cracked and uncracked concrete

Manufacturer

Rawplug S.A.
Ul. Kwidzyńska 6
51-416 Wrocław
Poland

Manufacturing plant

Manufacturing Plant No 2

**This European Technical Assessment
contains**

12 pages including 10 Annexes which form
an integral part of this assessment

**This European Technical Assessment is
issued in accordance with regulation
(EU) No 305/2011, on the basis of**

EAD 330232-00-0601

This version replaces

ETA 17/0185 issued on 20/03/2017

Translations of this European Technical Assessment in other languages shall fully correspond to the original issued document and should be identified as such.

Communication of this European Technical Assessment, including transmission by electronic means, shall be in full (excepted the confidential Annex(es) referred to above). However, partial reproduction may be made, with the written consent of the issuing Technical Assessment Body - Technical and Test Institute for Construction Prague. Any partial reproduction has to be identified as such

1. Technical description of the product

The Rawlplug R-HPTIIA4 Stainless Steel Throughbolts are through-fixing torque-controlled expansion anchors in sizes of M8, M10, M12 and M16. Each type comprises a special bolt with a taper, an expansion sleeve, a hexagonal nut and a washer. The anchors are made from A4 grade stainless steel.

The anchor is installed in a drilled hole; tightening the nut draws the cone into the sleeve. The expansion of this sleeve applies the anchorage.

The installed anchor is shown in Annex 1.

2. Specification of the intended use in accordance with the applicable EAD

The performances given in Section 3 are only valid if the anchor is used in compliance with the specifications and conditions given in Annex B.

The provisions made in this European Technical Assessment are based on an assumed working life of the anchor of 50 years. The indications given on the working life cannot be interpreted as a guarantee given by the producer, but are to be regarded only as a means for choosing the products in relation to the expected economically reasonable working life of the works.

3. Performance of the product and references to the methods used for its assessment

3.1 Mechanical resistance and stability (BWR 1)

Essential characteristic	Performance
Characteristic resistance (static and quasi-static loading)	See Annex C 1 and C 2
Displacement	See Annex C 1 and C 2
Characteristic resistance for seismic performance category C1	See Annex C 4

3.2 Safety in case of fire (BWR 2)

Essential characteristic	Performance
Reaction to fire	Class A1 according to EN 13501-1
Resistance to fire	Seen Annex C 3

4. Assessment and verification of constancy of performance (AVCP) system applied with reference to its legal base

According to the Decision 97/463/EC of the European Commission¹, the system 1 of assessment verification of constancy of performance (see Annex V to the Regulation (EU) No 305/2011) apply.

5. Technical details necessary for the implementation of the AVCP system, as provided in the applicable EAD

Technical details necessary for the implementation of the AVCP system are laid down in the control plan deposited at Technical and Test Institute for Construction Prague.

Issued in Prague on 02.10.2017

By

Ing. Mária Schaan

Head of the Technical Assessment Body

¹ Official Journal of the European Communities L 198/31 25.7.1997

Rawplug R-HPTIIA4 Stainless Steel Throughbolts - Installed anchor

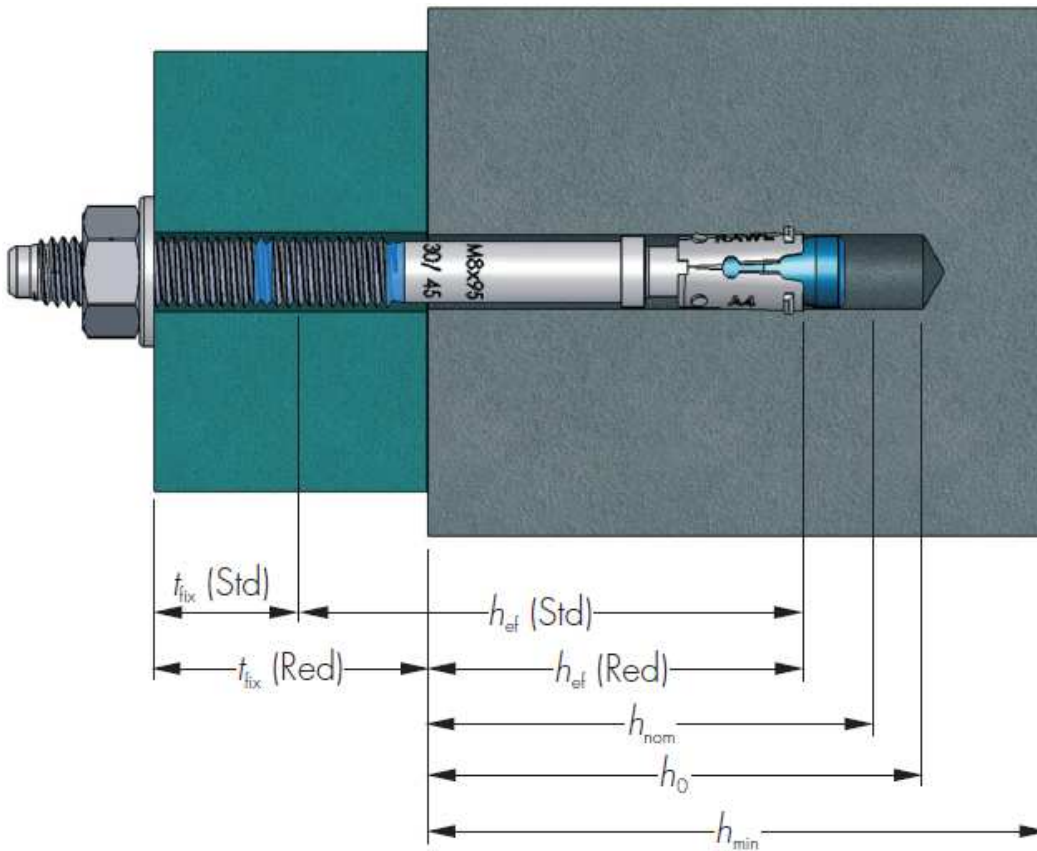

Rawplug R-HPTIIA4 Stainless Steel Throughbolts - components

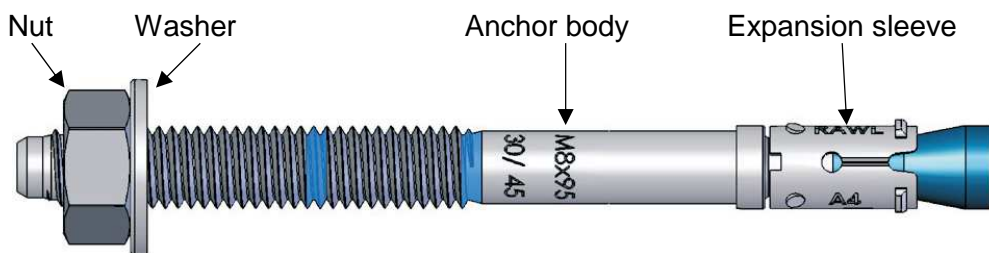

Rawplug R-HPTIIA4 Stainless Steel Throughbolts

Product description
Installed conditions and components

Annex A 1

Table A1 - Materials

Component	Material
Anchor body	Steel rod on coil cold forged bolts Steel grade 1.4578, according EN 10263-5
Expansion sleeve	Steel grade 1.4401, according EN 10088-2
Hexagonal nut	according DIN 934
Washer	according DIN 125A or DIN 9021

Table A2 – Material properties

Component		M8	M10	M12	M16
Anchor body – ultimate tensile strength	[N/mm ²]	600-700	600-700	550-650	550-650
Expansion sleeve – ultimate tensile strength	[N/mm ²]	530-680	530-680	530-680	530-680

Table A3 – Marking

M8																		
Bolt length [mm]	60	65	75	80	85	90	95	100	105	115	120	140	150	160				
Head marking	B	b	C	d	D	e	E	F	f	G	H	K	L	M				
Bolt marking	-/10	-/15	10/25	15/30	20/35	25/40	30/45	35/50	40/55	50/65	55/70	75/90	85/100	95/110				
M10																		
Bolt length [mm]	65	80	85	90	95	115	120	130	140	150	180							
Head marking	B	D	d	e	E	G	H	J	K	L	P							
Bolt marking	-/5	-/20	5/25	10/30	15/35	35/55	40/60	50/70	60/80	70/90	100/120							
M12																		
Bolt length [mm]	80	100	105	110	115	120	125	135	140	150	160	180	200	220	240	250	260	280
Head marking	D	F	f	G	g	h	H	J	K	L	M	P	R	S	T	U	V	X
Bolt marking	-/5	5/25	10/30	15/35	20/40	25/45	30/50	40/60	45/65	55/75	65/85	85/105	105/125	125/145	145/165	155/175	165/185	185/205
M16																		
Bolt length [mm]	100	105	125	130	140	150	160	180	200	220	250	280	300					
Head marking	F	f	H	J	K	L	M	P	R	S	U	X	Y					
Bolt marking	-/5	-/10	5/25	10/30	20/40	30/50	40/60	60/80	80/100	100/120	130/150	160/180	180/200					

Rawlplug R-HPTIIA4 Stainless Steel Throughbolts
Product description
 Materials
 Marking
Annex A 2

Specifications of intended use

Anchorage subject to:

- Static and quasi-static load.
- Fire exposure
- Seismic performance category C1

Base materials

- Cracked or uncracked concrete.
- Reinforced or unreinforced normal weight concrete of strength class C20/25 at minimum and C50/60 at maximum according EN 206-1:2000-12.

Use conditions (Environmental conditions)

- Structures subject to dry internal conditions.
- Structures subject to external atmospheric exposure (including industrial and marine environment) or exposure to permanently damp internal condition, if no particular aggressive conditions exist.

Note: Particular aggressive conditions are e.g. permanent, alternating immersion in seawater or the splash zone of seawater, chloride atmosphere of indoor swimming pools or atmosphere with extreme chemical pollution (e.g. in desulphurization plants or road tunnels where de-icing materials are used).

Design:

- The anchorages are designed under the responsibility of an engineer experienced in anchorages and concrete work.
- Verifiable calculation notes and drawings are prepared taking account of the loads to be anchored. The position of the anchor is indicated on the design drawings.
- Anchorages under static or quasi-static actions are designed for design method A in accordance with FprEN 1992-4:2016
- Anchorages under fire exposure have to be designed in accordance with TR 020 and ETAG 001, Annex C or CEN/TS 1992-4:2009, Annex D
- Anchorages under seismic actions (cracked concrete) have to be designed in accordance with EOTA Technical Report TR 045 "Design of Metal Anchors under Seismic Action".

Installation:

- Anchor installation carried out by appropriately qualified personnel and under the supervision of the person responsible for technical matters of the site.
- Use of the anchor only as supplied by the manufacturer without exchanging any components of the anchor.
- Anchor installation in accordance with the manufacturer's specifications and drawings using the appropriate tools.
- Effective anchoring depth, edge distance and spacing not less than the specified values without minus tolerance.
- In case of aborted drill hole: new drilling at a minimum distance away of twice the depth of the aborted hole or smaller distance if the aborted drill hole is filled with high strength mortar and if under shear or oblique tension load it is not in the direction of load application.

Rawlplug R-HPTIIA4 Stainless Steel Throughbolts

Intended use
Specifications

Annex B 1

Table B1 - Installation parameters

Size	Drill hole diameter	Bolt length	Thread length	Hole diameter in fixture	Standard embedment				Reduced embedment				Installation torque
					Min. hole depth	Nominal embedment depth	Effective embedment depth	Max. fixture thickness	Min. hole depth	Nominal embedment depth	Effective embedment depth	Max. fixture thickness	
	d ₀ [mm]	l [mm]	l _G [mm]	d _f [mm]	h ₀ [mm]	h _{nom} [mm]	h _{ef} [mm]	t _{fix} [mm]	h ₀ [mm]	h _{nom} [mm]	h _{ef} [mm]	t _{fix} [mm]	T _{inst} [N.m]
M8	8	60	25	9	-	-	-	-	50	40	32	10	15
		65	30	9	-	-	-	-	50	40	32	15	
		75	35	9	65	55	47	10	50	40	32	25	
		80	40	9	65	55	47	15	50	40	32	30	
		85	45	9	65	55	47	20	50	40	32	35	
		90	50	9	65	55	47	25	50	40	32	40	
		95	55	9	65	55	47	30	50	40	32	45	
		100	60	9	65	55	47	35	50	40	32	50	
		105	65	9	65	55	47	40	50	40	32	55	
		115	75	9	65	55	47	50	50	40	32	65	
		120	80	9	65	55	47	55	50	40	32	70	
		140	100	9	65	55	47	75	50	40	32	90	
150	100	9	65	55	47	85	50	40	32	100			
160	100	9	65	55	47	95	50	40	32	110			
M10	10	65	21	11	-	-	-	-	59	49	39	5	30
		80	31	11	-	-	-	-	59	49	39	20	
		85	36	11	79	69	59	5	59	49	39	25	
		90	41	11	79	69	59	10	59	49	39	30	
		95	46	11	79	69	59	15	59	49	39	35	
		115	66	11	79	69	59	35	59	49	39	55	
		120	71	11	79	69	59	40	59	49	39	60	
		130	81	11	79	69	59	50	59	49	39	70	
		140	91	11	79	69	59	60	59	49	39	80	
150	101	11	79	69	59	70	59	49	39	90			
180	100	11	79	69	59	100	59	49	39	120			
M12	12	80	30	13	-	-	-	-	70	60	48	5	50
		100	40	13	90	80	68	5	70	60	48	25	
		105	45	13	90	80	68	10	70	60	48	30	
		110	50	13	90	80	68	15	70	60	48	35	
		115	55	13	90	80	68	20	70	60	48	40	
		120	60	13	90	80	68	25	70	60	48	45	
		125	65	13	90	80	68	30	70	60	48	50	
		135	75	13	90	80	68	40	70	60	48	60	
		140	80	13	90	80	68	45	70	60	48	65	
		150	90	13	90	80	68	55	70	60	48	75	
		160	100	13	90	80	68	65	70	60	48	85	
		180	100	13	90	80	68	85	70	60	48	105	
		200	100	13	90	80	68	105	70	60	48	125	
		220	100	13	90	80	68	125	70	60	48	145	
		240	100	13	90	80	68	145	70	60	48	165	
250	100	13	90	80	68	155	70	60	48	175			
260	100	13	90	80	68	165	70	60	48	185			
280	100	13	90	80	68	185	70	60	48	205			
M16	16	100	30	18	-	-	-	-	90	80	65	5	100
		105	35	18	-	-	-	-	90	80	65	10	
		125	45	18	110	100	85	5	90	80	65	25	
		130	50	18	110	100	85	10	90	80	65	30	
		140	60	18	110	100	85	20	90	80	65	40	
		150	70	18	110	100	85	30	90	80	65	50	
		160	80	18	110	100	85	40	90	80	65	60	
		180	100	18	110	100	85	60	90	80	65	80	
		200	100	18	110	100	85	80	90	80	65	100	
		220	100	18	110	100	85	100	90	80	65	120	
		250	100	18	110	100	85	130	90	80	65	150	
280	100	18	110	100	85	160	90	80	65	180			
300	100	18	110	100	85	180	90	80	65	200			

Rawlplug R-HPTIIA4 Stainless Steel Throughbolts

Intended use
Installation parameters

Annex B 2

Table B2 - Installation parameters – Minimum spacing and edge distance

Size	M8		M10		M12		M16		
	Red ¹⁾	Std	Red ¹⁾	Std	Red	Std	Red	Std	
Minimum thickness of concrete member h_{min} [mm]	100	100	100	120	100	140	130	170	
Minimum spacing and edge distance in cracked concrete									
Minimum spacing s_{min} [mm]	50	55	70	70	120	90	150	135	
for edge distance $c \geq$ [mm]	50	55	70	70	95	75	100	105	
Minimum edge distance c_{min} [mm]	40	40	50	45	70	55	85	70	
for spacing $s \geq$ [mm]	80	70	120	90	150	140	200	200	
Minimum spacing and edge distance in uncracked concrete									
Minimum spacing s_{min} [mm]	50	55	70	70	120	90	150	135	
for edge distance $c \geq$ [mm]	50	55	70	70	95	75	100	105	
Minimum edge distance c_{min} [mm]	50	40	60	50	70	55	90	80	
for spacing $s \geq$ [mm]	50	100	70	115	120	125	150	200	

¹⁾ Use restricted to anchoring statically indeterminate structural components

Pre-torque installation

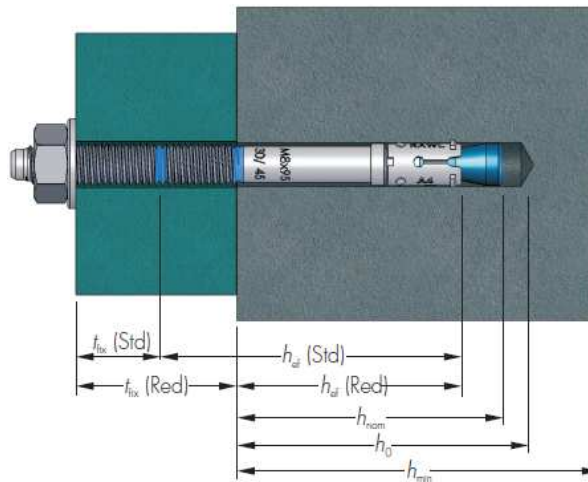

Post-torque installation

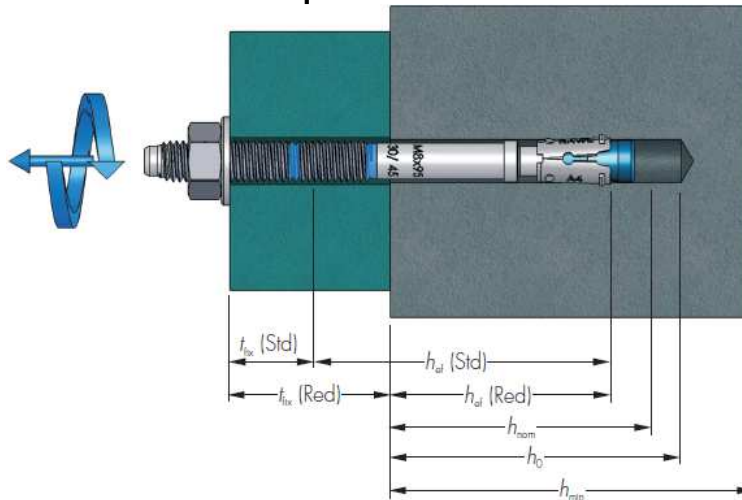

Rawlplug R-HPTIIA4 Stainless Steel Throughbolts

Intended use
Installation parameters

Annex B 3

Installation instructions

1.



Drill a hole of required diameter and depth

2.



Clear the hole of drilling dust and debris (using blowpump or equivalent method)

3.



Lightly tap the throughbolt through the fixture into hole with a hammer, until fixing depth is reached

4.



Tighten to the recommended torque

5.



Assembled condition of anchor

Rawlplug R-HPTIIA4 Stainless Steel Throughbolts

Intended use
Installation instructions

Annex B 4

Table C1 – Characteristic resistance under tension load

Steel failure										
Size			M8		M10		M12		M16	
			Red ¹⁾	Std	Red ¹⁾	Std	Red	Std	Red	Std
Characteristic resistance	$N_{Rk,s}$	[kN]	21,2		33,6		44,8		82,6	
Partial safety factor	γ_{Ms}	[-]	1,5		1,5		1,5		1,5	

Pull-out failure										
Characteristic resistance in cracked concrete C20/25	$N_{Rk,p}$	[kN]	3,0	6,0	7,5	9,0	9,0	12,0	16,0	25,0
Characteristic resistance in uncracked concrete C20/25	$N_{Rk,p}$	[kN]	7,5	9,0	12,0	16,0	- ⁵⁾	25,0	- ⁵⁾	- ⁵⁾
Installation safety factor	$\gamma_2^{2)} = \gamma_{inst}^{3)4)}$	[-]	1,2	1,2	1,2	1,0	1,0	1,0	1,0	1,0
Increasing factor										
Cracked and uncracked concrete	C30/37		1,07	1,16	1,07	1,26	1,16	1,23	1,18	1,18
	C40/50	ψ_c	1,13	1,33	1,13	1,52	1,32	1,45	1,37	1,37
	C50/60		1,20	1,50	1,20	1,78	1,49	1,67	1,55	1,55

Concrete cone failure										
Factor for uncracked concrete	$k_1^{2)} = k_{ucr}^{3)}$	[-]	10,1							
	$k_{ucr,N}^{4)}$	[-]	11,0							
Factor for cracked concrete	$k_1^{2)} = k_{ucr}^{3)}$	[-]	7,2							
	$k_{ucr,N}^{4)}$	[-]	7,7							
Installation safety factor	$\gamma_2^{2)} = \gamma_{inst}^{3)4)}$	[-]	1,2	1,2	1,2	1,0	1,0	1,0	1,0	1,0
Effective anchorage depth	h_{ef}	[mm]	32	47	39	59	48	68	65	85
Spacing	$s_{cr,N}$	[mm]	96	141	117	177	144	204	195	255
Edge distance	$c_{cr,N}$	[mm]	48	71	59	89	72	102	98	128

Splitting failure										
Spacing	$s_{cr,sp}$	[mm]	160	240	200	300	250	340	320	430
Edge distance	$c_{cr,sp}$	[mm]	80	120	100	150	125	170	160	215
Installation safety factor	$\gamma_2^{2)} = \gamma_{inst}^{3)4)}$	[-]	1,2	1,2	1,2	1,0	1,0	1,0	1,0	1,0

- ¹⁾ Use restricted to anchoring statically indeterminate structural components
- ²⁾ parameter for design according to EOTA ETAG 001 Annex C
- ³⁾ parameter for design according to CEN/TS 1992-4-4:2009
- ⁴⁾ parameter for design according to FprEN 1992-4:2016
- ⁵⁾ Pull-out failure mode is not decisive

Table C2 – Displacement under tension load

Size			M8		M10		M12		M16	
			Red ¹⁾	Std	Red ¹⁾	Std	Red	Std	Red	Std
Tension load in cracked concrete	N	[kN]	1,2	2,4	3,0	4,3	4,3	5,7	7,6	11,9
Displacement	δ_{N0}	[mm]	1,1	0,5	0,5	1,2	0,8	1,0	0,2	1,0
	$\delta_{N\infty}$	[mm]	1,8	1,3	0,8	1,2	1,0	1,3	0,6	1,1
Tension load in uncracked concrete	N	[kN]	3,0	3,6	4,8	7,6	8,0	11,9	12,6	18,8
Displacement	δ_{N0}	[mm]	0,1	0,3	0,2	0,2	0,1	0,5	0,3	0,5
	$\delta_{N\infty}$	[mm]	0,8	1,3	0,8	1,2	1,0	1,3	0,6	1,1

- ¹⁾ Use restricted to anchoring statically indeterminate structural components

Rawplug R-HPTIIA4 Stainless Steel Throughbolts	Annex C 1
Performances	
Characteristic resistance under tension load Displacement under tension load	

Table C3 – Characteristic resistance under shear load

Steel failure without lever arm			M8		M10		M12		M16	
			Red ¹⁾	Std	Red ¹⁾	Std	Red	Std	Red	Std
Size										
Characteristic resistance	$V_{Rk,s}^0$ [kN]		11,7		18,5		24,6		45,4	
Ductility factor	k_7 [-]		0,8		0,8		0,8		0,8	
Partial safety factor	γ_{Ms} [-]		1,25		1,25		1,25		1,25	

Steel failure with lever arm			M8		M10		M12		M16	
Characteristic resistance	$M_{Rk,s}^0$ [Nm]		22		45		72		180	
Partial safety factor	γ_{Ms} [-]		1,25		1,25		1,25		1,25	

Concrete pry-out failure			M8		M10		M12		M16	
Factor	k_8 [-]		1,2	1,2	1,2	1,2	1,2	1,2	1,2	1,2
Installation safety factor	$\gamma_2^{2)} = \gamma_{inst}^{3)4)}$ [-]		1,2	1,2	1,2	1,2	1,2	1,2	1,2	1,2

Concrete edge failure			M8		M10		M12		M16	
Effective length of anchor	l_f [mm]		32	47	39	59	48	68	65	85
Anchor diameter	d_{nom} [mm]		8		10		12		16	
Installation safety factor	$\gamma_2^{2)} = \gamma_{inst}^{3)4)}$ [-]		1,2	1,2	1,2	1,0	1,0	1,0	1,0	1,0

- ¹⁾ Use restricted to anchoring statically indeterminate structural components
- ²⁾ parameter for design according to EOTA ETAG 001 Annex C
- ³⁾ parameter for design according to CEN/TS 1992-4-4:2009
- ⁴⁾ parameter for design according to FprEN 1992-4:2016

Table C4 – Displacement under shear load

Size			M8		M10		M12		M16	
			Red ¹⁾	Std	Red ¹⁾	Std	Red	Std	Red	Std
Shear load in cracked and uncracked concrete	V [kN]		6,7	6,7	5,8	10,6	14,1	14,1	25,9	25,9
Displacement	δ_{v0} [mm]		3,0	3,0	1,5	2,7	2,5	2,5	2,2	2,2
	$\delta_{v\infty}$ [mm]		4,5	4,5	2,2	4,1	3,8	3,8	3,8	3,3

- ¹⁾ Use restricted to anchoring statically indeterminate structural components

Rawplug R-HPTIIA4 Stainless Steel Throughbolts	Annex C 2
Performances	
Characteristic resistance under shear load Displacement under shear load	

Table C5 – Characteristic values of resistance to tension load under fire exposure¹⁾

Size	M8		M10		M12		M16		
	Red ²⁾	Std	Red ²⁾	Std	Red	Std	Red	Std	
Characteristic fire resistance duration at 30 minutes									
Steel failure	$N_{Rk,s,fi}$ [kN]	0,7	0,7	1,5	1,5	2,5	2,5	4,7	4,7
Pull-out failure	$N_{Rk,p,fi}$ [kN]	0,8	1,5	1,9	2,3	2,3	3,0	4,0	6,3
Concrete cone failure	$N_{Rk,c,fi}$ [kN]	1,0	2,7	1,7	4,8	2,9	6,9	6,1	12,0
Characteristic fire resistance duration at 60 minutes									
Steel failure	$N_{Rk,s,fi}$ [kN]	0,6	0,6	1,2	1,2	2,1	2,1	3,9	3,9
Pull-out failure	$N_{Rk,p,fi}$ [kN]	0,8	1,5	1,9	2,3	2,3	3,0	4,0	6,3
Concrete cone failure	$N_{Rk,c,fi}$ [kN]	1,0	2,7	1,7	4,8	2,9	6,9	6,1	12,0
Characteristic fire resistance duration at 90 minutes									
Steel failure	$N_{Rk,s,fi}$ [kN]	0,4	0,4	0,9	0,9	1,7	1,7	3,1	3,1
Pull-out failure	$N_{Rk,p,fi}$ [kN]	0,8	1,5	1,9	2,3	2,3	3,0	4,0	6,3
Concrete cone failure	$N_{Rk,c,fi}$ [kN]	1,0	2,7	1,7	4,8	2,9	6,9	6,1	12,0
Characteristic fire resistance duration at 120 minutes									
Steel failure	$N_{Rk,s,fi}$ [kN]	0,4	0,4	0,8	0,8	1,3	1,3	2,5	2,5
Pull-out failure	$N_{Rk,p,fi}$ [kN]	0,6	1,2	1,5	1,8	1,8	2,4	3,2	5,0
Concrete cone failure	$N_{Rk,c,fi}$ [kN]	0,8	2,2	1,4	3,9	2,3	5,5	4,9	9,6
Spacing	$S_{cr,N}$ [mm]	4 x h_{ef}							
	S_{min} [mm]	50	55	70	70	120	90	150	135
Edge distance	$C_{cr,N}$ [mm]	2 x h_{ef}							
	C_{min} [mm]	$C_{min} = 2 \times h_{ef}$ however if the fire attack is from more than one side, the edge distance of the anchor has to be ≥ 300 mm and $\geq 2 \times h_{ef}$							

¹⁾ In absence of other national regulations the partial safety factor for resistance under fire exposure. $\gamma_{M,fi} = 1,0$ is recommended

²⁾ Use restricted to anchoring statically indeterminate structural components

Table C6 – Characteristic values of resistance to shear load under fire exposure



Size	M8		M10		M12		M16		
	Red ¹⁾	Std	Red ¹⁾	Std	Red ¹⁾	Std	Red	Std	
Characteristic fire resistance duration at 30 minutes									
Steel failure without lever arm	$V_{Rk,s,fi}$ [kN]	0,7		1,5		2,5		4,7	
Steel failure with lever arm	$M_{Rk,s,fi}$ [Nm]	0,7		1,9		3,9		10,0	
Characteristic fire resistance duration at 60 minutes									
Steel failure without lever arm	$V_{Rk,s,fi}$ [kN]	0,6		1,2		2,1		3,9	
Steel failure with lever arm	$M_{Rk,s,fi}$ [Nm]	0,6		1,5		3,3		8,3	
Characteristic fire resistance duration at 90 minutes									
Steel failure without lever arm	$V_{Rk,s,fi}$ [kN]	0,4		0,9		1,7		3,1	
Steel failure with lever arm	$M_{Rk,s,fi}$ [Nm]	0,4		1,2		2,6		6,7	
Characteristic fire resistance duration at 120 minutes									
Steel failure without lever arm	$V_{Rk,s,fi}$ [kN]	0,4		0,8		1,3		2,5	
Steel failure with lever arm	$M_{Rk,s,fi}$ [Nm]	0,4		1,0		2,1		5,3	
Concrete pry-out failure									
Factor ²⁾	k_8 [-]	-	-	1,2	-	-	-	-	-
Concrete edge failure The characteristic resistance $V_{Rk,c,fi}^0$ in concrete C20/25 to C50/60 is determined by: $V_{Rk,c,fi}^0 = 0,25 \times V_{Rk,c}^0$ and $V_{Rk,c,fi}^0 = 0,20 \times V_{Rk,c}^0$ with the initial value of the characteristic resistance $V_{Rk,c}^0$ in cracked concrete C20/25 under normal temperature									

¹⁾ Use restricted to anchoring statically indeterminate structural components

²⁾ The values of factor k_8 and relevant values of $N_{Rk,c,fi}$ given in the Table C5 have to be considered in the design

Rawplug R-HPTIIA4 Stainless Steel Throughbolts	Annex C 3
Performances Characteristic values of resistance under fire exposure	

Table C7 – Characteristic values of resistance under seismic action category C1

Size			M8		M10		M12		M16	
			Red ¹⁾	Std	Red ¹⁾	Std	Red ¹⁾	Std	Red ¹⁾	Std
Tension load										
Steel failure										
Characteristic resistance	$N_{Rk,s,eq}$	[kN]	21,2		33,6		44,8		82,6	
Partial safety factor	$\gamma_{Ms,eq}$	[-]	1,5		1,5		1,5		1,5	
Pull-out failure										
Characteristic resistance in concrete C20/25	$N_{Rk,p,eq}$	[kN]	3,0	6,0	7,5	9,0	9,0	12,0	16,0	25,0
Installation safety factor	$\gamma_{Mp,eq}$	[-]	1,2	1,2	1,2	1,0	1,0	1,0	1,0	1,0
Shear load										
Steel failure without lever arm										
Characteristic resistance	$V^0_{Rk,s,eq}$	[kN]		6,7		12,5	18,4	39,0		
Partial safety factor	$\gamma_{Ms,eq}$	[-]	1,25		1,25		1,25		1,25	

¹⁾ Use restricted to anchoring statically indeterminate structural components

Rawplug R-HPTIIA4 Stainless Steel Throughbolts

Performances
Reduction factors for seismic design

Annex C 4